

020-2505-00 Solder-in Accessory Kit for Differential Probes

020-2506-00 Resistor/Wire Kit for Solder-in Adapters

Instructions

071-1266-02



071126602

This kit is a new standard accessory for your differential probe and may not be listed in your Instruction Manual or Accessory Reorder Sheet. New kits can also be ordered separately.

Kit Contents

These instructions are included with the following two kits:

- Tektronix part number 020-2505-00, Solder-in Accessory kit: Includes 2 solder-in adapters and the Resistor/Wire kit shown in the illustration below.

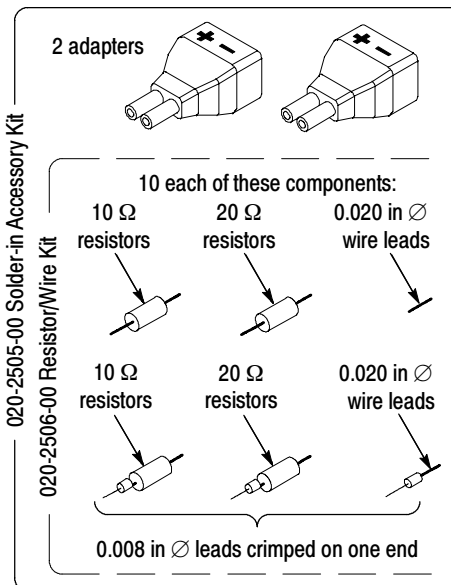

- Tektronix part number 020-2506-00, Resistor/Wire kit. The kit includes the resistors and wire leads shown above.

Use the resistors with crimped-on 0.008-inch diameter wire leads when you need to connect to smaller-diameter vias on your circuit board.

Order the Resistor/Wire kit for replenishing the resistors and wire from your Solder-in Accessory kit.

Overview

The Solder-in Accessory kit allows you to create a customized, hands-free connection from your circuit to P6330 and TekConnect® P73XX Series differential probes.

The adapters use low-insertion force sockets that provide a break-away feature to protect your probe and circuitry from damage by excessive forces on the probe cable.

The adapter easily connects and disconnects to the probe head. You can connect several adapters throughout your circuit to gain access to difficult test points quickly and easily.

The elastomeric contacts inside the adapter are rated for 50-75 insertion cycles with the probe tip. Replace the adapter after exceeding these limits to avoid unreliable operation.

Using the Accessory Kit

Before you begin soldering accessory components to your circuit, consider the following points:

- You can use this kit to browse your circuit as well as creating a soldered connection.
- The adapter-side of the resistor leads are precut to ~0.110 inch so that the resistor bodies touch the adapter sockets when fully inserted.
- Cut the circuit-side resistor leads as short as possible, and keep the lengths matched for best signal integrity. (See Table 1 for typical electrical characteristics).
- The adapter cannot support the weight of the attached probe. Therefore, before you solder the resistors or wires to the circuit board, position the probe to the circuit board to relieve strain on the adapter and solder connections.
- You can use 0.020-inch diameter pins or wire instead of resistors, but do not insert anything larger than a 0.022-inch diameter pin into the adapter, or you will damage the adapter.
- Do not use this adapter for square pins. Instead, use the square pin adapter, Tektronix part number 016-1884-XX.
- Do not solder the adapter directly.
- To avoid damaging the probe, disconnect the probe from the adapter before soldering components.
- Only use ESD-approved soldering irons and no-clean flux solder when soldering components to your circuit.

Procedure

Refer to the illustrations as you follow these steps:

1. Connect the resistors or wires to the adapter. Push the resistors all the way into the adapter sockets, so that the resistor bodies touch the sockets.
2. Verify that both resistors or wires can reach your test points, and that you can locate the adapter in a secure position.
3. Cut the resistor or wire leads (as short as possible and the same length, see Table 1), and solder them to the circuit.
4. When needed, use an adhesive such as quick-set epoxy or hot glue, to secure the resistors or wires to the circuit board.
5. Gently push the probe into the adapter until it seats against the probe head.
6. Secure the probe to the circuit board with tape or hook-and-loop strips.

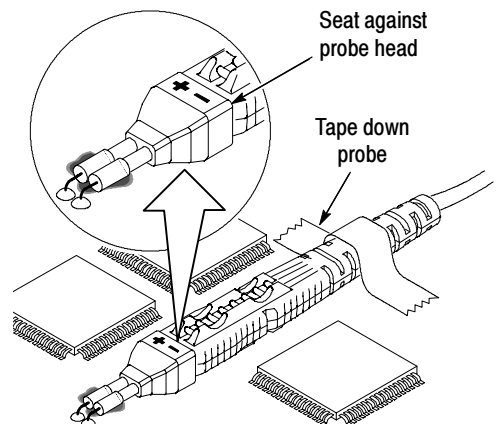
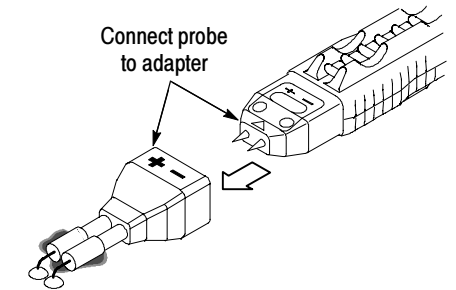
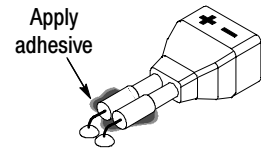
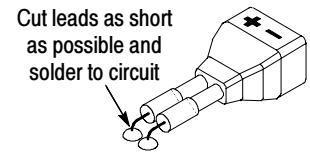
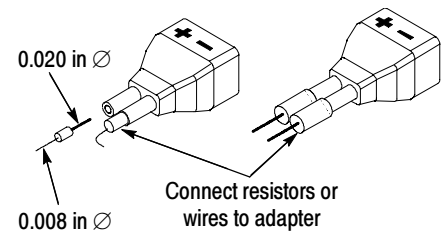

Resistor and Wire Lead Lengths

The resistors included with this kit have leads that are precut to 0.110 inch on one side for inserting into the adapter. This length ensures good contact with the adapter.

Cut the circuit-side of the resistors very short. See Table 1 for typical electrical characteristics of the adapter using various lead lengths and resistor values.

Use Table 1 to help you select the component configuration that optimizes response for bandwidth, rise time, or overshoot, based on your measurement needs.

If you use components not included with this kit, keep the circuit-side lead lengths as short as possible, and adapter-side lead lengths between 0.110 and 0.130 inches.

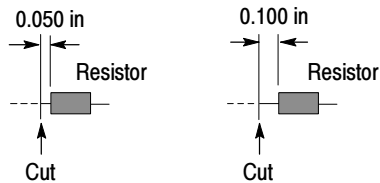
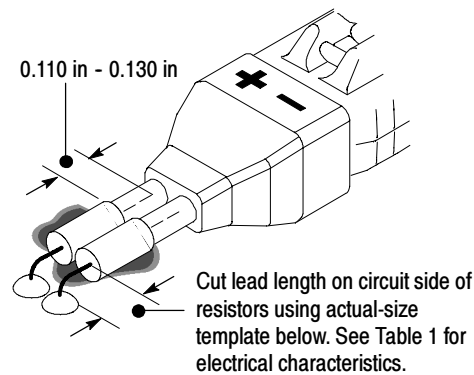

Dimensions

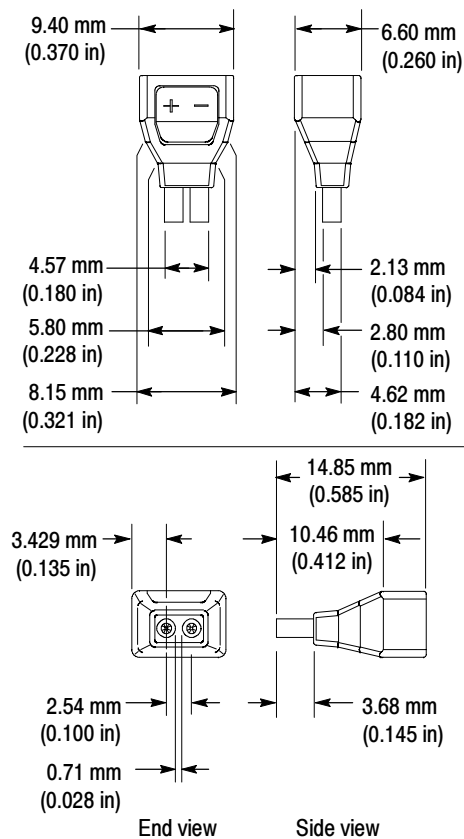

WARRANTY SUMMARY

Tektronix warrants that the products that it manufactures and sells will be free from defects in materials and workmanship for a period of three (3) months from the date of shipment from an authorized Tektronix distributor. If a product or CRT proves defective within the respective period, Tektronix will provide repair or replacement as described in the complete warranty statement.

To arrange for service or obtain a copy of the complete warranty statement, please contact your nearest Tektronix sales and service office.

EXCEPT AS PROVIDED IN THIS SUMMARY OR THE APPLICABLE WARRANTY STATEMENT, TEKTRONIX MAKES NO WARRANTY OF ANY KIND, EXPRESS OR IMPLIED, INCLUDING WITHOUT LIMITATION THE IMPLIED WARRANTIES OF MERCHANTABILITY AND FITNESS FOR A PARTICULAR PURPOSE. IN NO EVENT SHALL TEKTRONIX BE LIABLE FOR INDIRECT, SPECIAL OR CONSEQUENTIAL DAMAGES.

Table 1: Typical electrical characteristics with a 110 ps (10-90%) input step

| Resistor value and lead length on circuit side ¹ | P6330 and P7330 Probe | | | | P7350 Probe | | | |
|---|------------------------|---|----------------------|-----------|------------------------|---|----------------------|-----------|
| | Bandwidth ² | Probe rise time with 110 ps (10-90%) input step | | | Bandwidth ² | Probe rise time with 110 ps (10-90%) input step | | |
| | | 10-90 % ³ | 20-80 % ³ | Overshoot | | 10-90 % ³ | 20-80 % ³ | Overshoot |
| Probe only (reference) | 4.3 GHz | 139 ps | 94 ps | 4% | >5 GHz | 127 ps | 85 ps | 10% |
| Wire, 0.050" | 4.5 GHz | 124 ps | 85 ps | 15% | >5 GHz | 114 ps | 77 ps | 14% |
| Wire, 0.100" | 4.3 GHz | 122 ps | 82 ps | 21% | >5 GHz | 111 ps | 76 ps | 22% |
| 10 Ω, 0.050" | 3.9 GHz | 130 ps | 87 ps | 19% | 4.5 GHz | 120 ps | 81 ps | 18% |
| 10 Ω, 0.100" | 3.8 GHz | 131 ps | 95 ps | 23% | 4.0 GHz | 120 ps | 81 ps | 21% |
| 20 Ω, 0.050" | 3.8 GHz | 137 ps | 94 ps | 10% | 4.2 GHz | 129 ps | 87 ps | 9% |
| 20 Ω, 0.100" | 3.7 GHz | 140 ps | 94 ps | 14% | 3.9 GHz | 128 ps | 87 ps | 13% |

¹ Increasing the resistance decreases overshoot. Increasing the lead length increases overshoot.

² Measured using a network analyzer.

³ Using a 110 ps-step source. With a faster source, warranted 10-90% rise times are ≤140 ps for the P6330/P7330, and ≤100 ps for the P7350.